

NOTES: UNLESS OTHERWISE SPECIFIED

1. SEE DRAWING NO. CB-00278 AND PROCEDURE P-1000 FOR ASSEMBLY AND TEST INSTRUCTION. PROCEDURES AND ASSEMBLY DRAWINGS ARE FOR INTERNAL USE ONLY.
2. ALL TESTING IS PERFORMED IAW BATTERY COUNCIL INTERNATIONAL STANDARDS.
3. DIMENSIONS ARE INCH [MILLIMETER].
4. ALTERNATE BOLT KIT PROVIDED, PART NUMBER 6924.

DISTRIBUTION NOTES:

Issued to Lifeline/DJ Godber

08/09/23

REVISIONS			
REV	DESCRIPTION	DATE	APPROVED
A	REMOVED SIDE HOLD-DOWNS	5/14/02	JBT
B	REDESIGNED COVER	6/26/18	PH
C	STANDARDIZED ENVELOPE, ADDED NOTE 4	7/21/20	PH
D	REVISED CONTAINER	11/10/21	PH

**UNCONTROLLED
FOR REFERENCE ONLY**

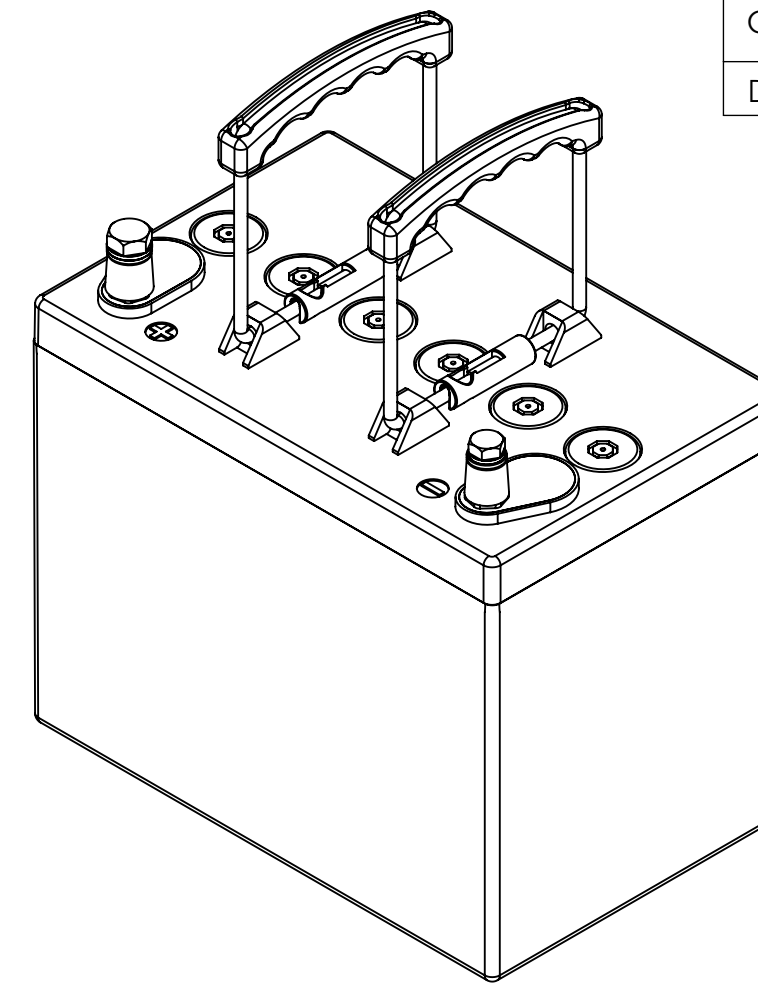
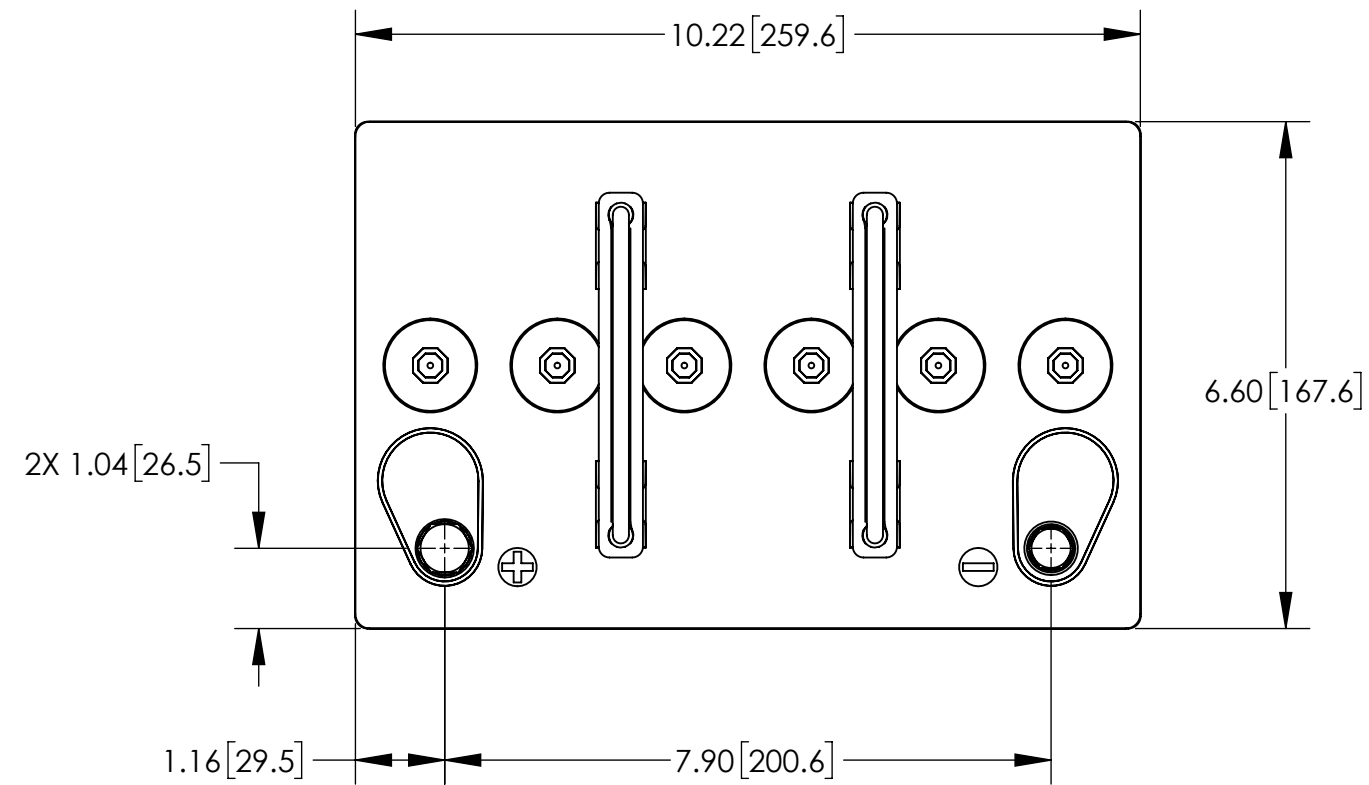

ISOMETRIC VIEW

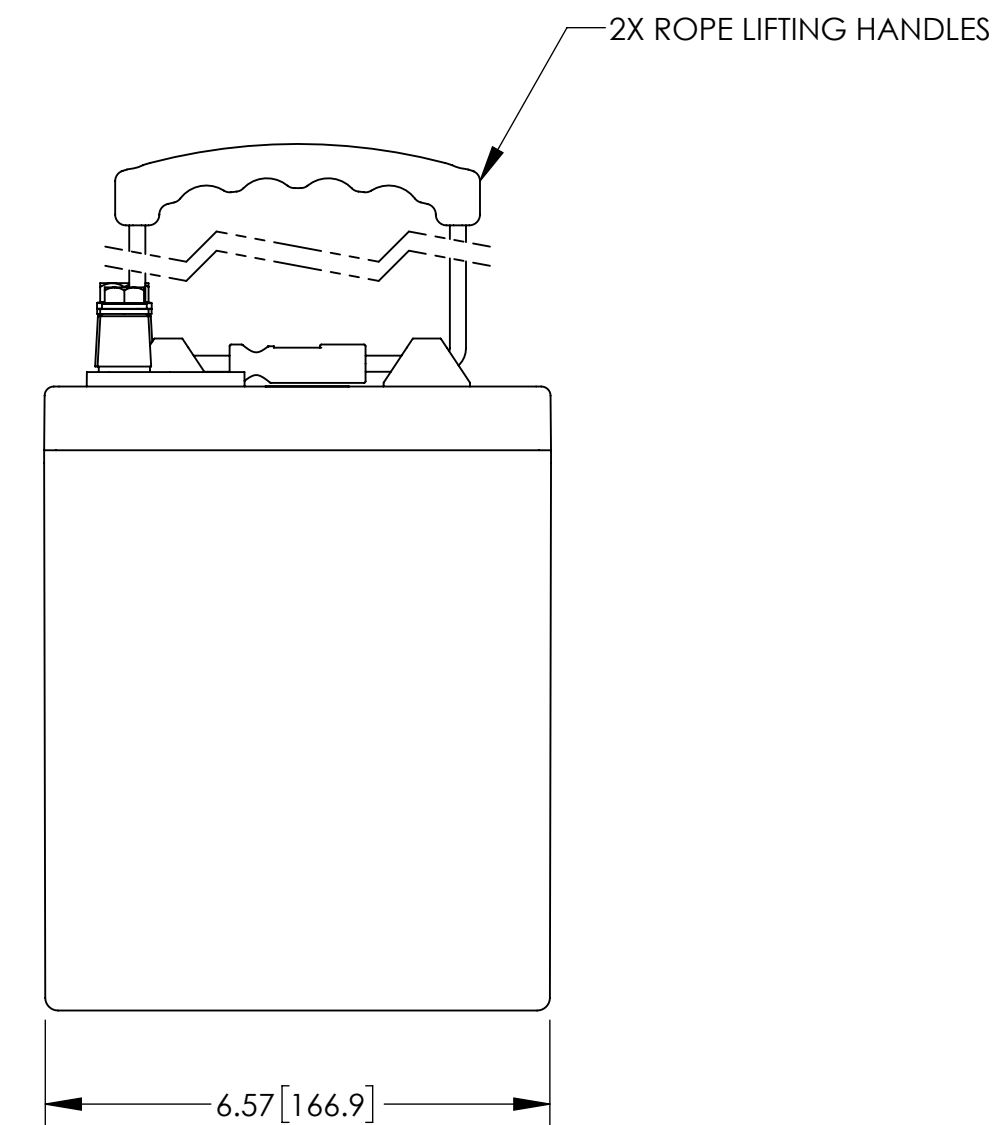
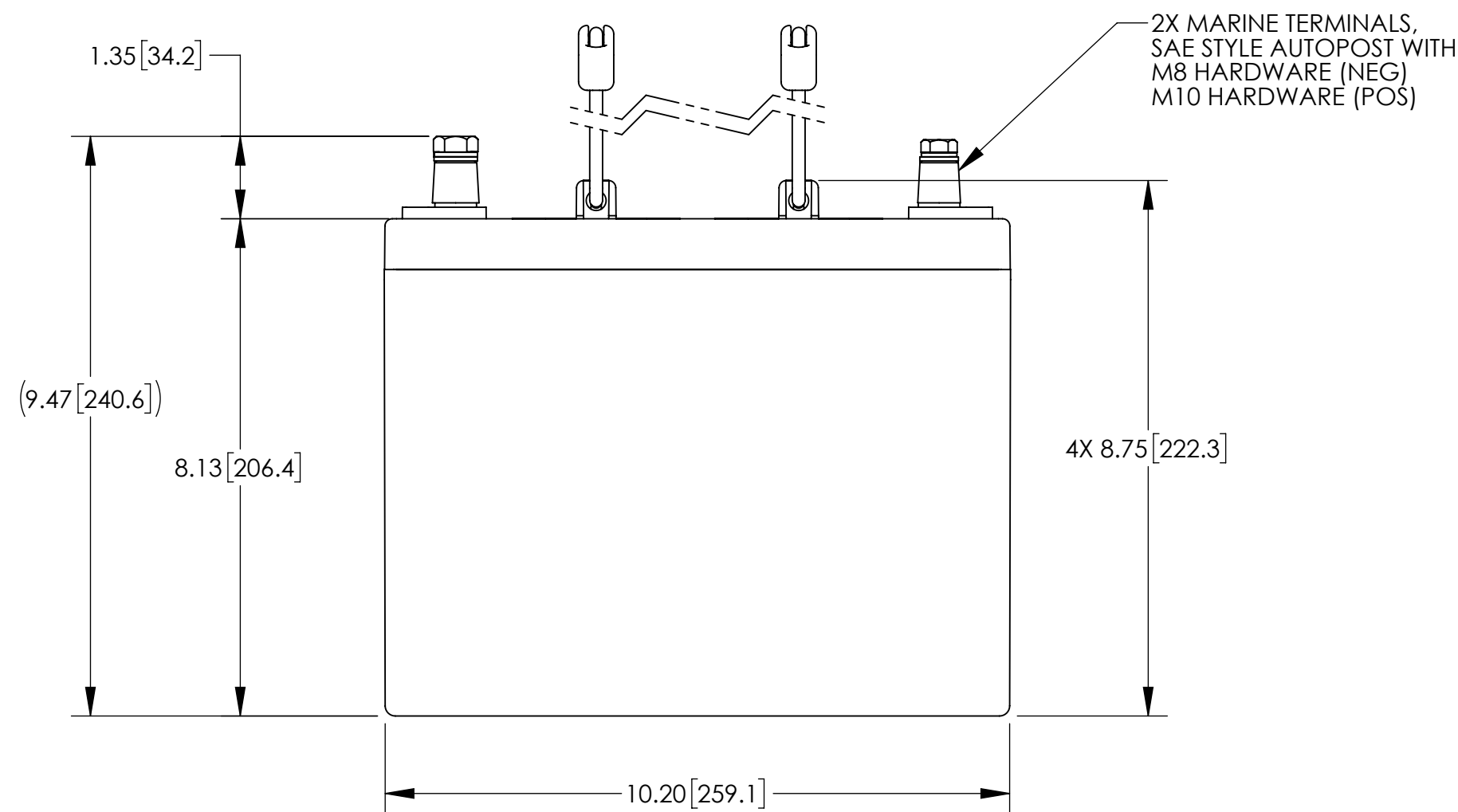

CAPACITY RATINGS	
PART NUMBER	GPL-24T
NOMINAL WEIGHT	56 LBS [25.5 KG]
AMPERE HOUR CAPACITY @ 20 HOUR 1.75 VOLTS/CELL @ 70°F (25°C)	80 AH
MINUTES OF DISCHARGE @ 25 AMPS 1.75 VOLTS/CELL @ 77°F (25°C)	149 MIN

ENVELOPE DRAWING

UNLESS OTHERWISE SPECIFIED DIMENSIONS ARE IN INCHES TOLERANCES ARE:			CONTRACT NO. <small>This document contains data which is PROPRIETARY to Concorde Battery Corporation. Any use thereof is subject to the proprietary interest of Concorde. No data is to be disclosed to others without the written permission of Concorde Battery Corporation.</small>		CONCORDE BATTERY CORPORATION 2009 SAN BERNARDINO RD, W. COVINA, CA 91790		
FRACTIONS	DECIMALS	ANGLES	APPROVALS	DATE	TITLE		
±1/32	.XX ± .12 .XXX ± .060	±1°	DRAWN ELH	3/13/00	BATTERY, 12 VOLT, GPL-24T		
TREATMENT	NONE		CHECKED S. VALDEZ	3/13/00	SIZE	CAGE CODE	DWG NO.
FINISH	NONE		APPROVED JBT	3/16/00	C	63017	GPL-24T
SIMILAR TO	CALC WT		ISSUED DH	11/17/21	SCALE	1:2.5	REV D
							SHEET 1 OF 1