

NOTES: UNLESS OTHERWISE SPECIFIED

1. SEE DRAWING NO. CB-00358 AND PROCEDURE P-1000 FOR ASSEMBLY AND TEST INSTRUCTION. PROCEDURES AND ASSEMBLY DRAWINGS ARE FOR INTERNAL USE ONLY.
2. ALL TESTING IS PERFORMED IAW BATTERY COUNCIL INTERNATIONAL STANDARDS.
3. ALL DIMENSIONS ARE INCH [MM].
4. TERMINAL HARDWARE PROVIDED.

REVISIONS			
REV	DESCRIPTION	DATE	APPROVED

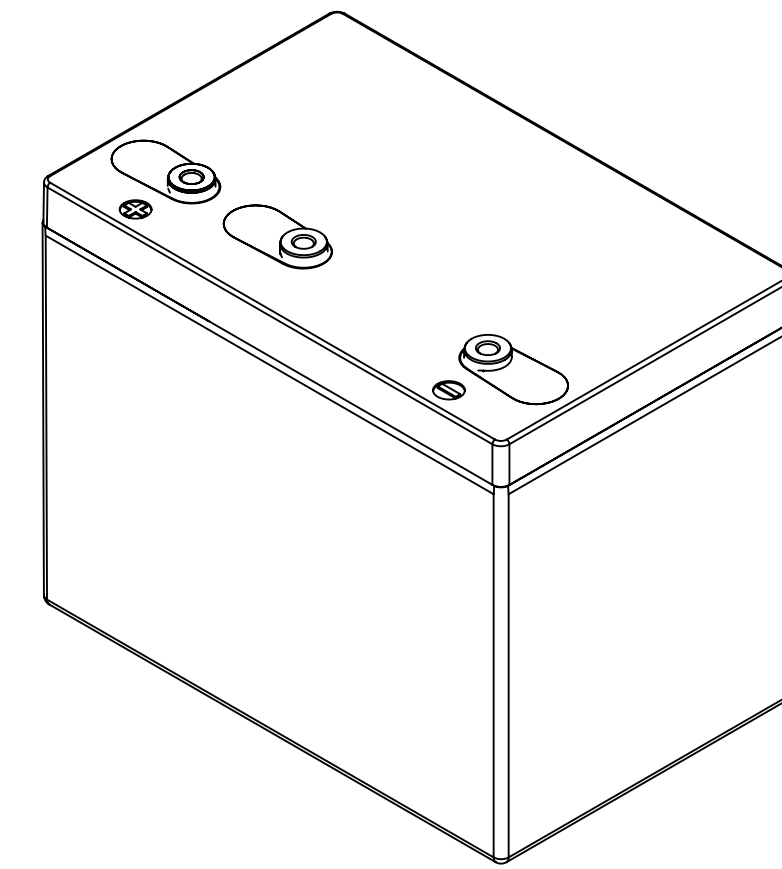
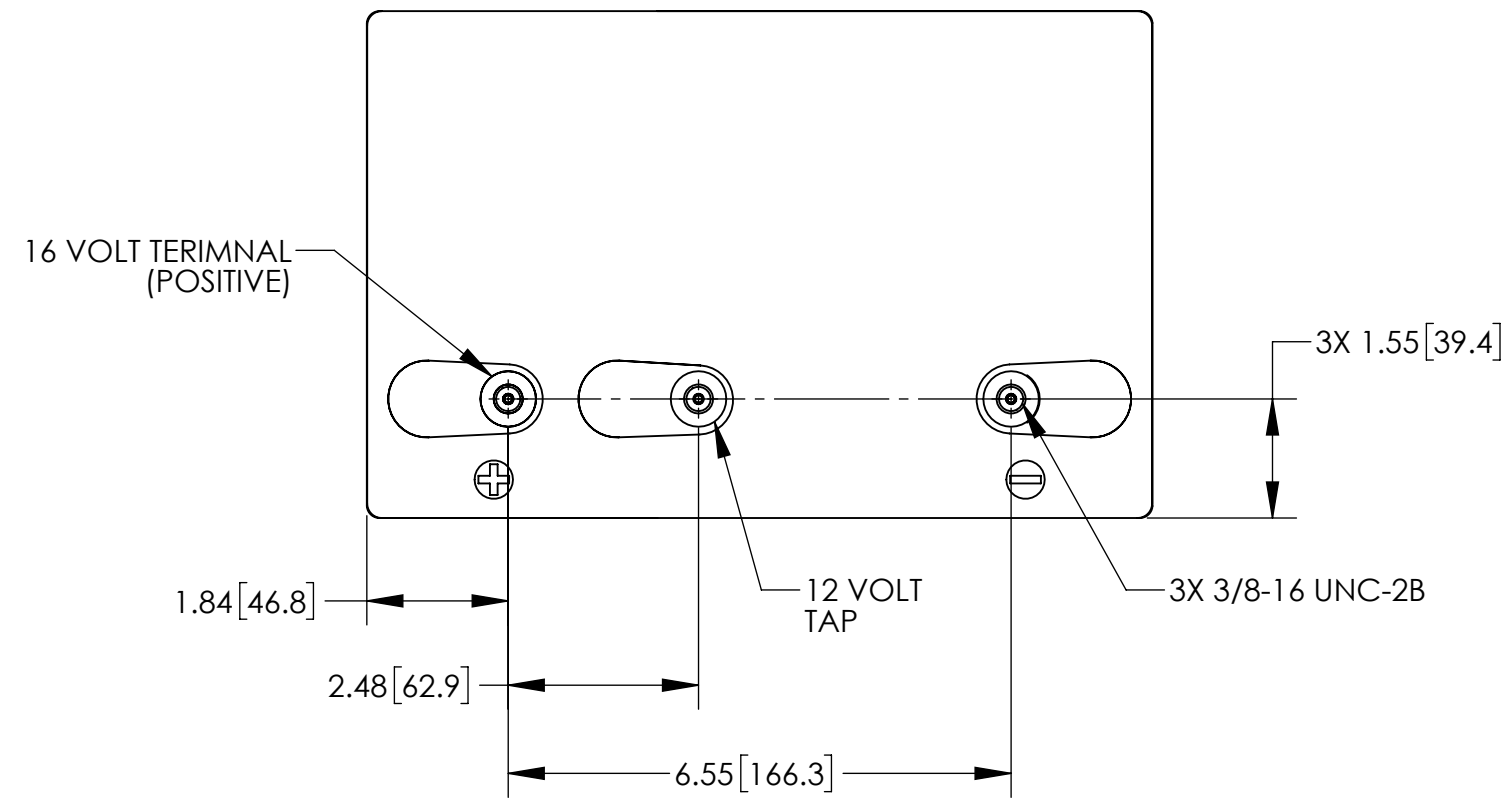

REFERENCE VIEW

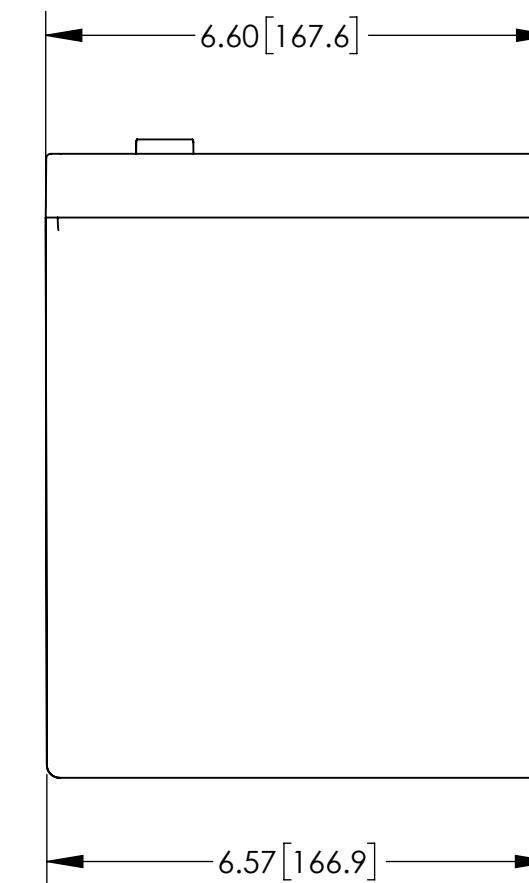
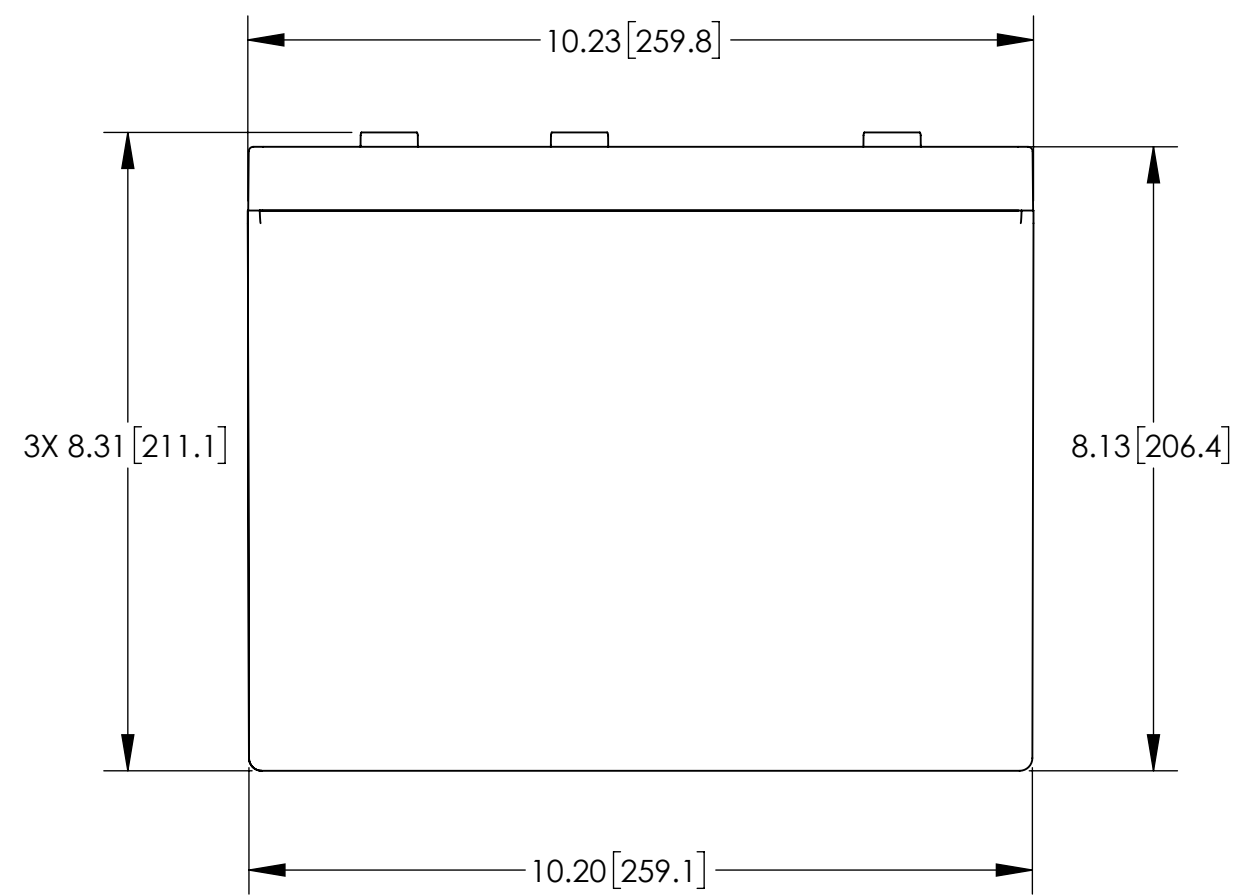

PART NUMBER	LL-16/1240TB
NOMINAL WEIGHT	43 LBS [19.5 KG]
NOMINAL VOLTAGE	16/12 V
AMPERE HOUR CAPACITY @ 20 HOUR 1.75 VOLTS/CELL @ 77° F (25°C)	40
MINUTES OF DISCHARGE @ 25 AMPS 1.75 VOLTS/CELL @ 77° F (25°C)	85

ENVELOPE DRAWING

UNLESS OTHERWISE SPECIFIED DIMENSIONS ARE IN INCHES TOLERANCES ARE:			CONTRACT NO.		CONCORDE BATTERY CORPORATION 2009 SAN BERNARDINO RD, W. COVINA, CA 91790		
FRACTIONS	DECIMALS	ANGLES	APPROVALS	DATE	TITLE		
±1/32	.XX ± .12 .XXX ± .060	±1°	DRAWN J.DENDIU	8/2/24	BATTERY, 12/16 VOLT, LL-16/1240TB		
TREATMENT	NONE	CHECKED NS	8/7/24	SIZE	CAGE CODE	DWG NO.	REV
FINISH	NONE	APPROVED PH	8/8/24	C	63017	LL-16/1240TB	
SIMILAR TO	CALC WT	ISSUED DH	8/8/24	SCALE	1:2.5	SHEET	1 OF 1