

NOTES: UNLESS OTHERWISE SPECIFIED

1. SEE DRAWING NO. CB-00293 AND PROCEDURE P-1000 FOR ASSEMBLY AND TEST INSTRUCTION. PROCEDURES AND ASSEMBLY DRAWINGS ARE FOR INTERNAL USE ONLY.
2. ALL TESTING ARE IAW BATTERY COUNCIL INTERNATIONAL STANDARDS.
3. ALL DIMENSIONS ARE IN INCHES [MM].

REVISIONS			
REV	DESCRIPTION	DATE	APPROVED
A	REV TERM SIZE WAS: M8 X 1.25	12/23/00	JBT
B	REVISED NOTE 1	8/29/16	JG

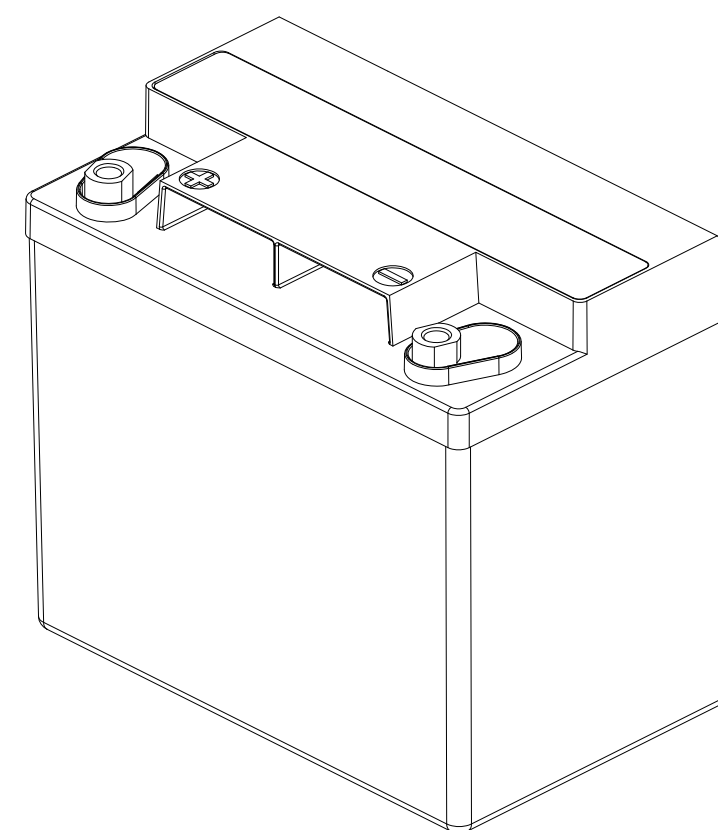
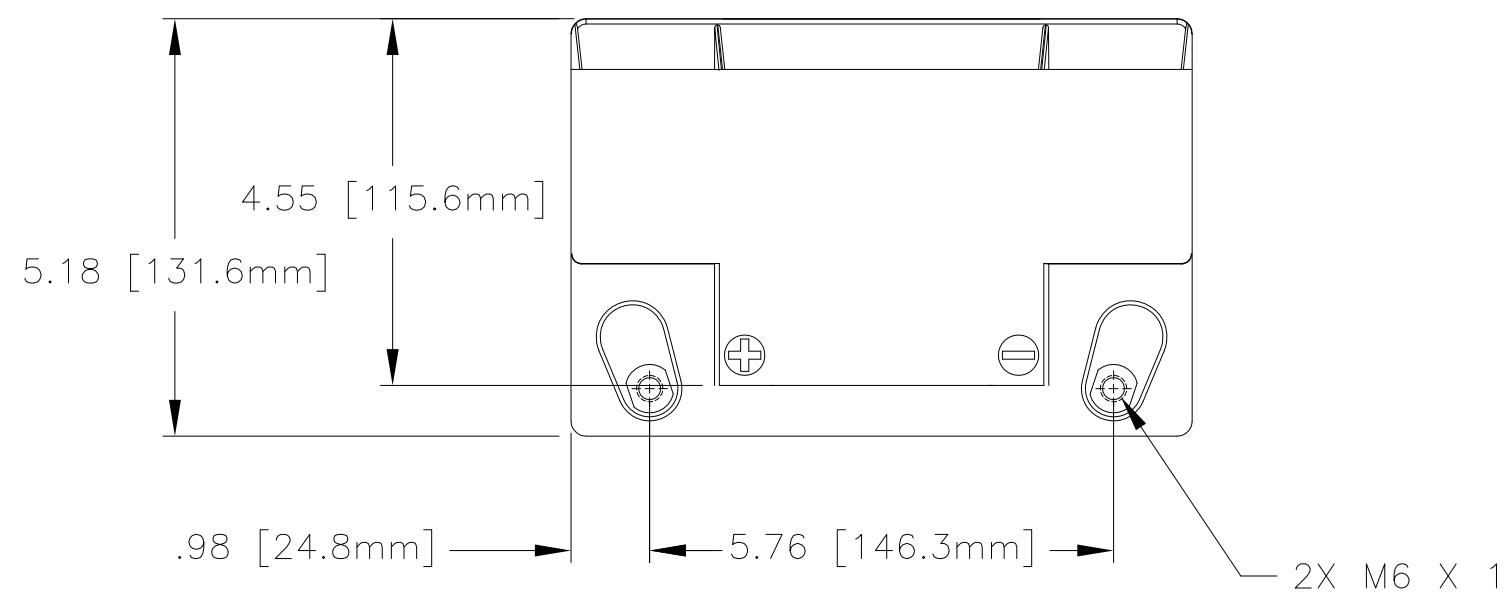

REFERENCE VIEW

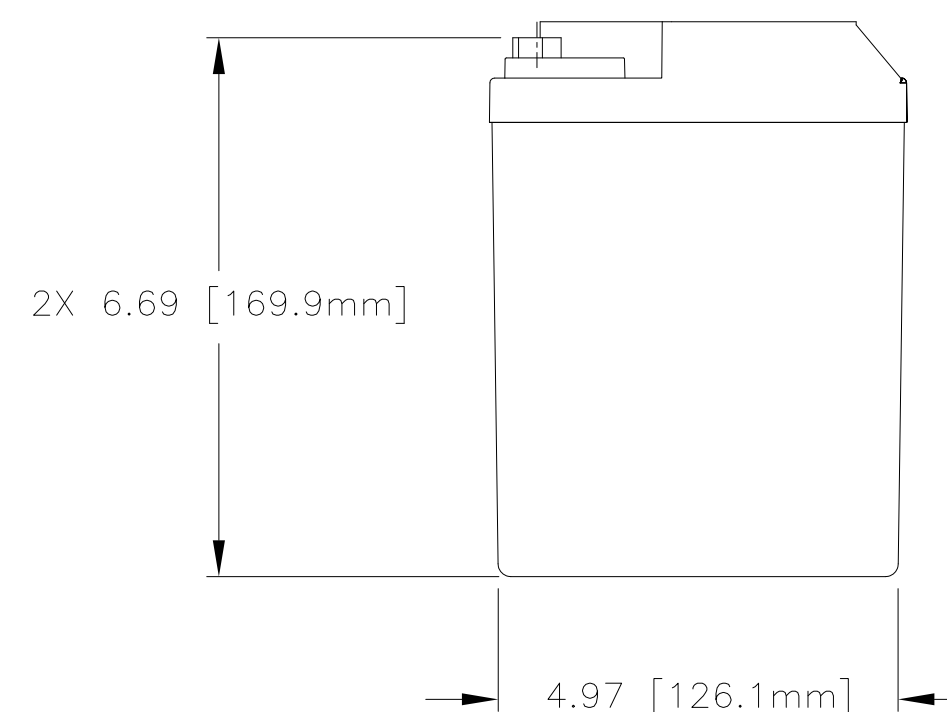
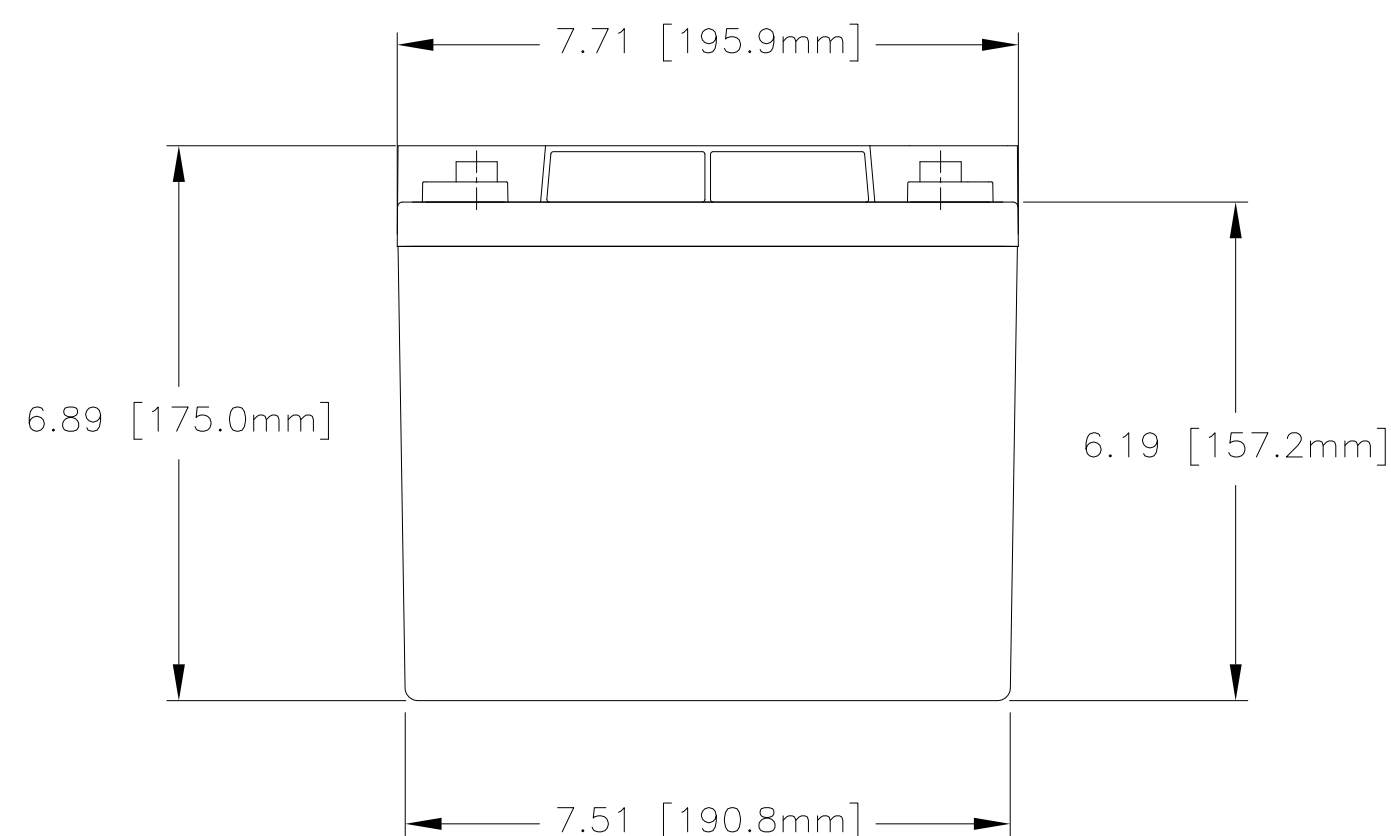

CAPACITY RATINGS	
PART NUMBER	GPL-U1T
NOMINAL WEIGHT	24 LBS[10.9 KG]
AMPERE HOUR CAPACITY @ 20 HOUR 1.75 VOLTS/CELL @ 77°F (25° C)	33 AH
MINUTES OF DISCHARGE @ 25 AMPS 1.75 VOLTS/CELL @ 77°F (25° C)	50 MIN

ENVELOPE DRAWING

QTY REQD	CAGE CODE	PART OR IDENTIFYING NO.	NOMENCLATURE OR DESCRIPTION	MATERIAL SPECIFICATION	ITEM NO.
PARTS LIST					
UNLESS OTHERWISE SPECIFIED DIMENSIONS ARE IN INCHES TOLERANCES ARE:			CONTRACT NO.		
FRACTIONS DECIMALS ANGLES			TITLE		
.XX ± .06			CONCORDE BATTERY CORPORATION		
.XXX ± .060			2009 SAN BERNARDINO RD, W. COVINA, CA 91790		
TREATMENT NONE			APPROVALS	DATE	
FINISH NONE			DRAWN ELH	3/22/00	BATTERY, 12 VOLT, GPL-U1T
SIMILAR TO N/A			CHECKED S. VALDEZ	3/22/00	SIZE C
ACT WT N/A			APPROVED DG	3/23/00	CAGE CODE 63017
CALC WT N/A			ISSUED JG	9/01/16	DWG NO. GPL-U1T
			SCALE NONE		REV B
			SHEET 1 OF 1		