

NOTES: UNLESS OTHERWISE SPECIFIED

1. SEE DRAWING NO. CB-00290 AND PROCEDURE P-1000 FOR ASSEMBLY AND TEST INSTRUCTION. PROCEDURES AND ASSEMBLY DRAWINGS ARE FOR INTERNAL USE ONLY.
2. ALL TESTING IS PERFORMED IAW BATTERY COUNCIL INTERNATIONAL STANDARDS.
3. ALL DIMENSIONS ARE INCH [MM].

REVISIONS			
REV	DESCRIPTION	DATE	APPROVED
A	SEE DCN GPL31TA	8/10/11	JBT

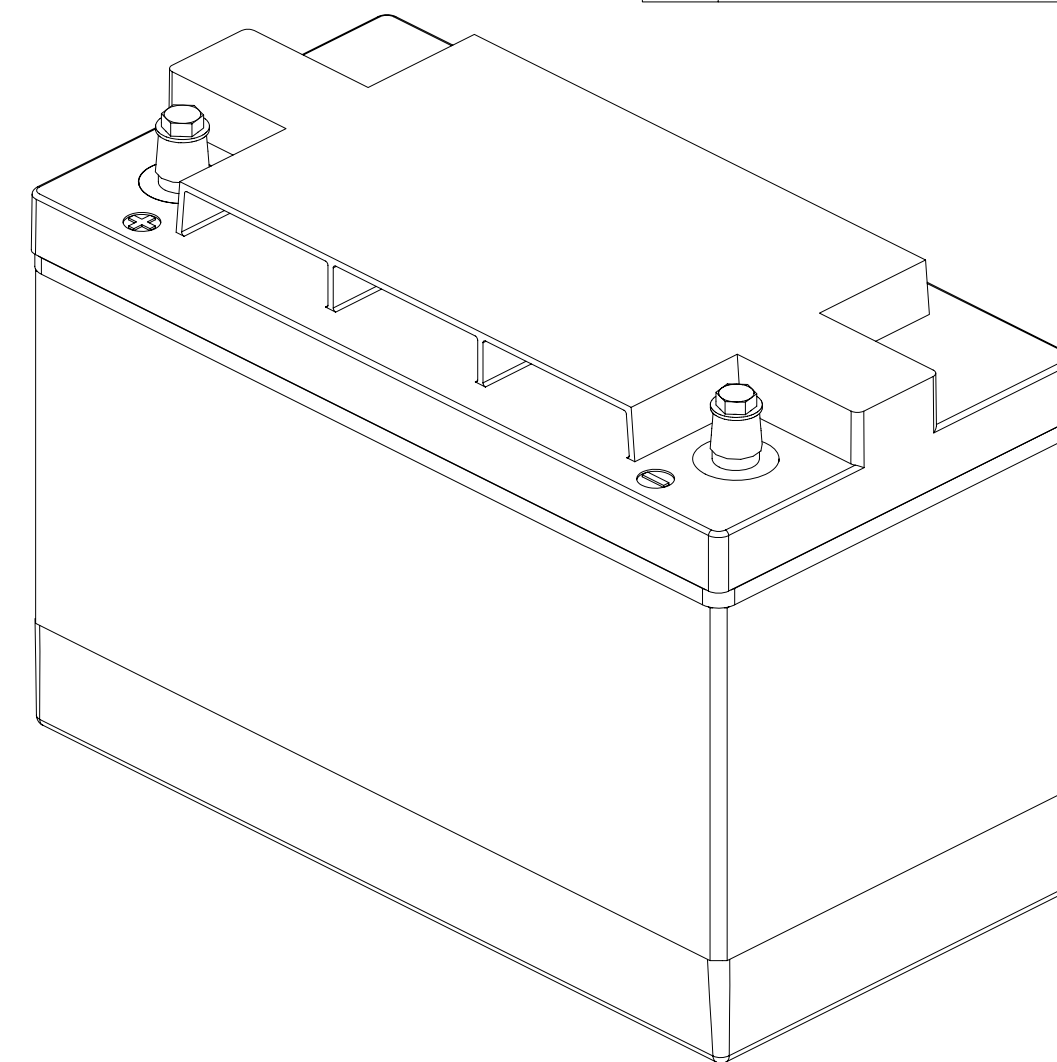

REFERENCE VIEW

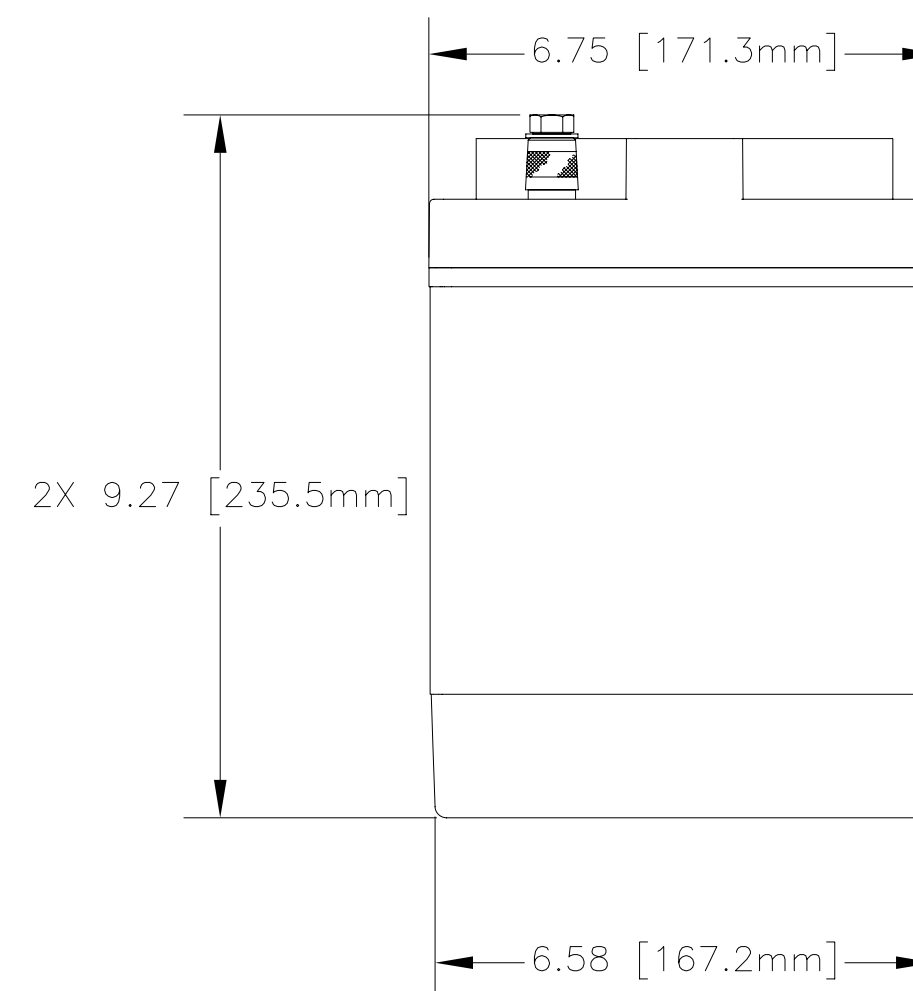
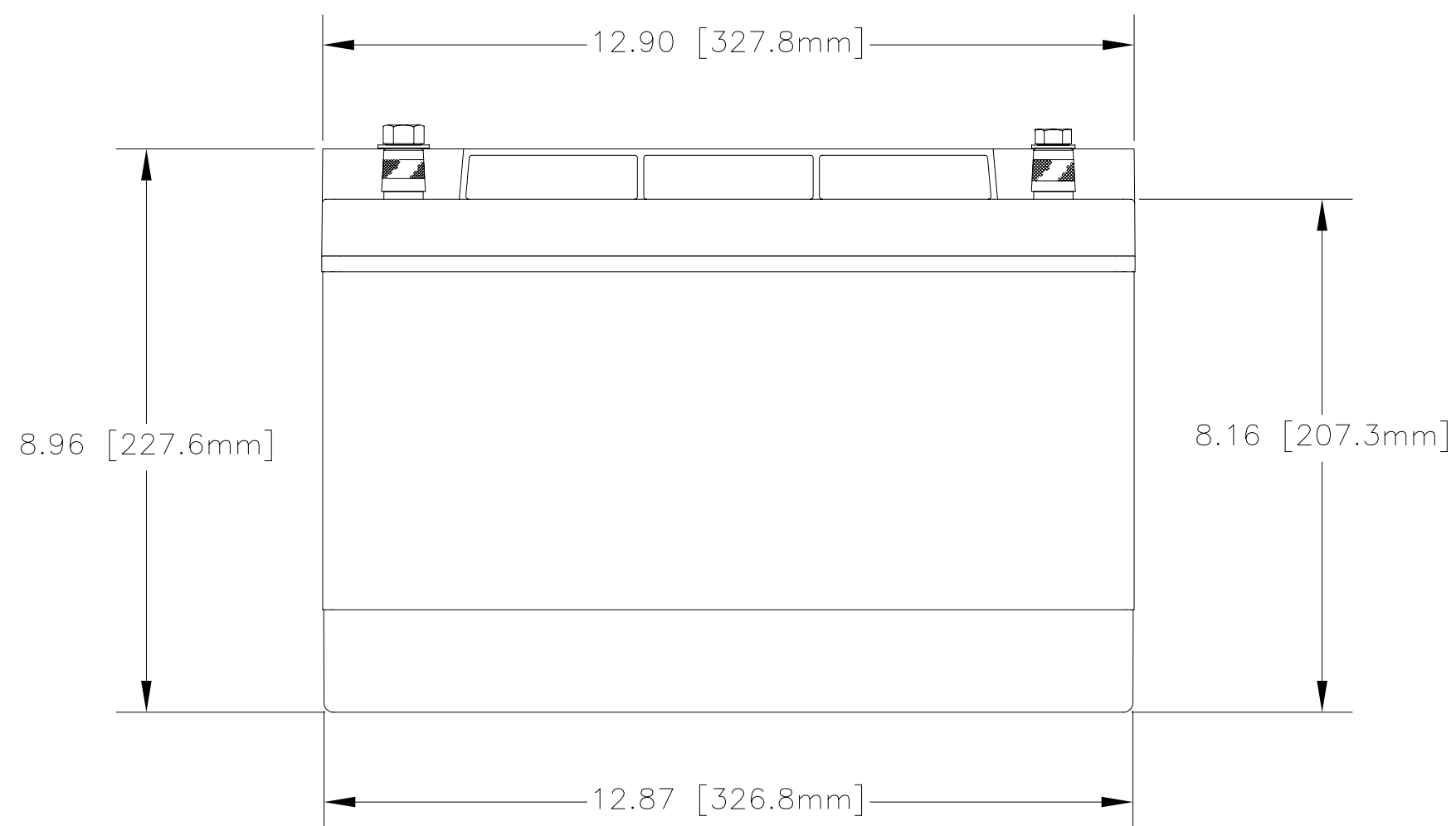
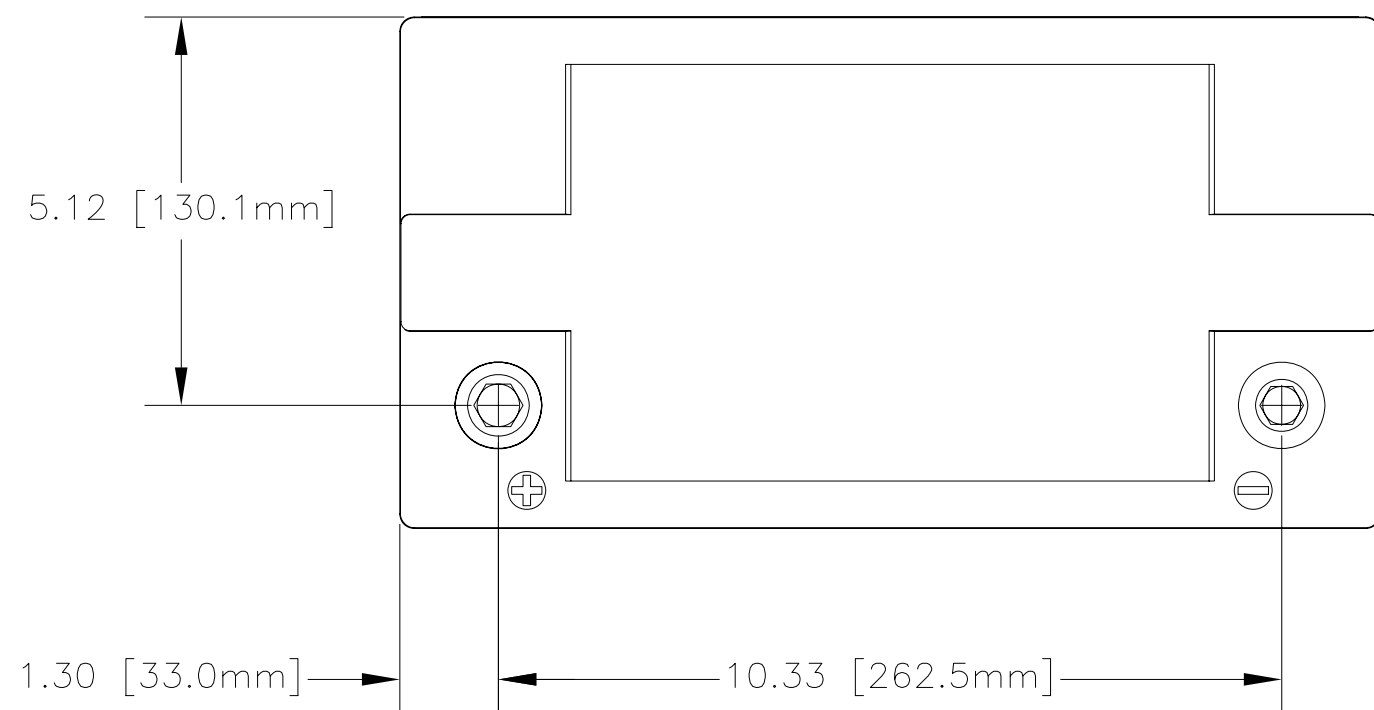

ENVELOPE DRAWING

CAPACITY RATE	
PART NUMBER	GPL-31T
NOMINAL WEIGHT	64 LBS [29 KG]
AMPERE HOUR CAPACITY @ 20 HOUR 1.75 VOLTS/CELL @ 77°F (25°C)	105 AH
MINUTES OF DICHARGE @ 25 AMPS 1.75 VOLTS/CELL @ 77°F (25°C)	195 MIN

QTY REQD	CAGE CODE	PART OR IDENTIFYING NO.	NOMENCLATURE OR DESCRIPTION	MATERIAL SPECIFICATION	ITEM NO.
PARTS LIST					
UNLESS OTHERWISE SPECIFIED DIMENSIONS ARE IN INCHES TOLERANCES ARE:			CONCORDE BATTERY CORPORATION 2009 SAN BERNARDINO RD, W. COVINA, CA 91790		
FRACTIONS	DECIMALS	ANGLES	APPROVALS	DATE	TITLE
.XX ± .06	.XXX ± .060		DRAWN ELH	3/13/00	BATTERY, 12 VOLT, GPL-31T
TREATMENT	NONE	CHECKED S. VALDEZ	APPROVED JBT	3/16/00	SIZE C
FINISH	NONE	ISSUED JJ	8/12/11	DWG NO. GPL-31T	REV A
SIMILAR TO	ACT WT	CALC WT	SCALE NONE	SHEET 1 OF 1	