

NOTES: UNLESS OTHERWISE SPECIFIED

1. SEE DRAWING NO. CB-00285 AND PROCEDURE P-1000 FOR ASSEMBLY AND TEST INSTRUCTION. PROCEDURES AND ASSEMBLY DRAWINGS ARE FOR INTERNAL USE ONLY.
2. ALL TESTS ARE IAW BATTERY COUNCIL INTERNATIONAL STANDARDS.
3. ALL DIMENSIONS ARE IN INCHES [MM].

REVISIONS			
REV	DESCRIPTION	DATE	APPROVED
A	REMOVED SIDE HOLD-DOWNS	6/10/03	JBT

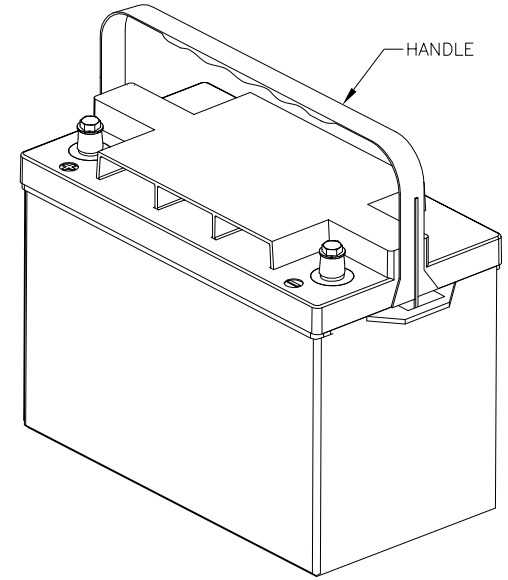
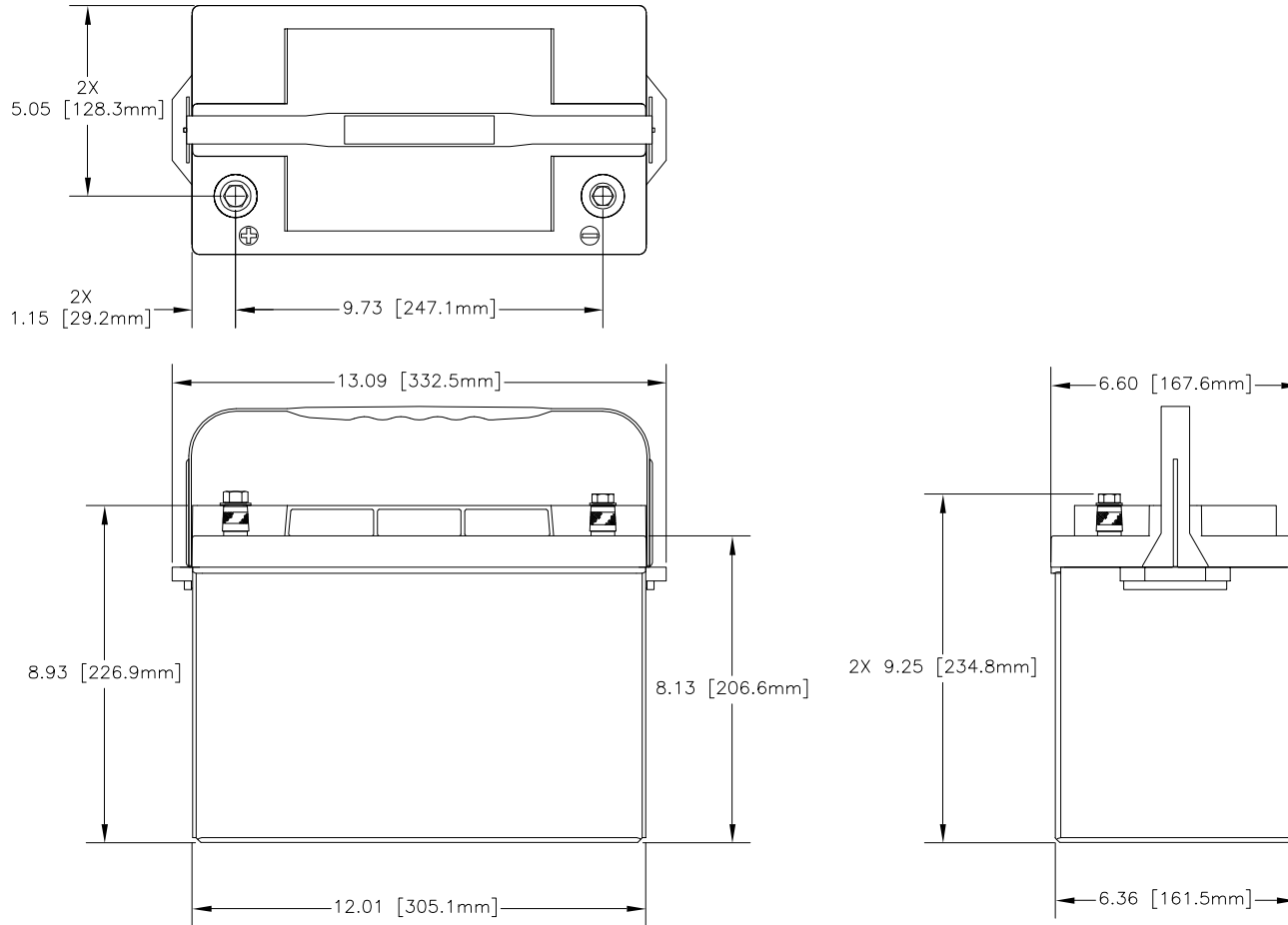

REFERENCE VIEW

CAPACITY RATINGS	
PART NUMBER	GPL-2700T
NOMINAL WEIGHT	63 LBS [28.6 KG]
AMPERE HOUR CAPACITY @ 20 HOUR 1.75 VOLTS/CELL @ 77°F (25°C)	95 AH
MINUTES OF DISCHARGE @ 25 AMPS 1.75 VOLTS/CELL @ 77°F (25°C)	206 MIN
COLD CRANKING AMPS @ 68°F	1020
COLD CRANKING AMPS @ 32°F	900
COLD CRANKING AMPS @ 0°F	745

ENVELOPE DRAWING

QTY REQD	CAGE CODE	PART OR IDENTIFYING NO.	NOMENCLATURE OR DESCRIPTION	MATERIAL SPECIFICATION	ITEM NO.
PARTS LIST					
UNLESS OTHERWISE SPECIFIED DIMENSIONS ARE IN INCHES. TOLERANCES ARE:			CONTRACT NO.		
FRACTIONS DECIMALS ANGLES			CONCORDE BATTERY CORPORATION		
± 1/32 .XX ± .06 ± 1°			2009 SAN BERNARDINO RD, W. COVINA, CA 91790		
.XXX ± .030			TITLE BATTERY, 12 VOLT, GPL-2700T		
APPROVALS		DATE		SIZE	
DRAWN S.FRAZIER		5/7/02		CAGE CODE	
CHECKED HRF		5/14/02		DWG NO.	
APPROVED JBT		5/17/02		GPL-2700T	
FINISH NONE		APPROVED JBT		REV A	
SIMILAR TO NA		ISSUED AT		SCALE NONE	
ACT WT NA		DLC WT NA		SHEET 1 OF 1	